

Research Article

DOI: <http://dx.doi.org/10.22192/ijamr.2018.05.12.009>

Arduino based lineman protection system with user interface circuit breaker

Dr. A. V. Prathap kumar, Dr. K. V. S. S. S. Sairam,

Dhanalakshmi Srinivasan Engineering College, Perambalur

Abstract

The project is designed to control a circuit breaker with help of a password only. A keypad is connected to the project to enter the password. Fatal electrical accidents to the line man are increasing during the electric line repair due to the lack of communication and co-ordination between the maintenance staff and the electric substation staff.

This proposed system provides a solution, which can ensure the safety of the maintenance staff e.g. line man. The control to turn ON/OFF the line lies with the line man only. This system has an arrangement such that a password is required to operate the circuit breaker (ON/OFF). Line man can turn off the supply and comfortably repair it, and return to the substation, then turn on the line by entering the correct password.

The system is fully controlled by a microcontroller from 8051 family. A matrix keypad is interfaced to the microcontroller to enter the password. The entered password is compared with the password stored in the ROM of the microcontroller. If the password entered is correct, then only the line can be turned ON/OFF. Activation / deactivation of the circuit breaker are indicated by a lamp (ON/OFF).

This project is enhanced by using an EEPROM for user to change the password for a more secured system. It can also be interfaced with a GSM modem for remotely monitoring the circuit breaker conditions via SMS.

Keywords

Resistors, Capacitors,
Diodes, Transistors,
Voltage regulator,
Rectifier,
Microcontroller,
EEPROM, Relay,
Relay Driver

I. Introduction

Nowadays, electrical accidents to the line man are increasing, while repairing the electrical lines due to the lack of communication between the electrical substation and maintenance staff. This project gives a solution to this problem to ensure line man safety. In this proposed system the control (ON/OFF) of the electrical lines lies with line man. This project is

arranged in such a way that maintenance staff or line man has to enter the password to ON/OFF the electrical line. Now if there is any fault in electrical line then line man will switch off the power supply to the line by entering password and comfortably repair the electrical line, and after coming to the substation line man switch on the supply to the particular line by entering the password.

II. Description

RESISTORS: A resistor is a two-terminal electronic component designed to oppose an electric current by producing a voltage drop between its terminals in proportion to the current, that is, in accordance with Ohm's law: $V = IR$. Resistors are used as part of electrical networks and electronic circuits. They are extremely common place in most electronic equipment. Practical resistors can be made of various compounds and films, as well as resistance wire.

CAPACITOR: A capacitor or condenser is a passive electronic component consisting of a pair of conductors separated by a dielectric. When a voltage potential difference exists between the conductors, an electric field is present in the dielectric. This field stores energy and produces a mechanical force between the plates. The effect is greatest between wide, flat, parallel, narrowly separated conductors.

DIODES: Diodes are used to convert AC into DC these are used as half wave rectifier or full wave rectifier. When used in its most common application, for conversion of an alternating current (AC) input into a direct current (DC) output, it is known as a bridge rectifier. A bridge rectifier provides full-wave rectification from a two-wire AC input, resulting in lower cost and weight as compared to a rectifier with a 3-wire input from a transformer with a center-tapped secondary winding

TRANSISTORS: A transistor is a semiconductor device used to amplify and switch electronic signals and electric power. It is composed of semiconductor material with at least three terminals for connection to an external circuit. A voltage or current applied to one pair of the transistor's terminals changes the current through another pair of terminals. Because the controlled (output) power can be higher than the controlling (input) power, a transistor can amplify a signal. Today, some transistors are packaged individually, but many more are found embedded in integrated circuits. The transistor is the fundamental building block of modern electronic devices, and is ubiquitous in modern electronic systems.

VOLTAGE REGULATOR: 7805 is a voltage regulator integrated circuit. It is a member of 78xx series of fixed linear voltage regulator ICs. The voltage source in a circuit may have fluctuations and would not give the fixed voltage output. The voltage regulator IC maintains the output voltage at a constant

value. The xx in 78xx indicates the fixed output voltage it is designed to provide. 7805 provides +5V regulated power supply. Capacitors of suitable values can be connected at input and output pins depending upon the respective voltage levels.

RECTIFIER: A rectifier is an electrical device that converts alternating current (AC), which periodically reverses direction, to direct current (DC), current that flows in only one direction, a process known as rectification.

MICROCONTROLLER: A microcontroller (sometimes abbreviated μC , uC or MUC) is a small computer on a single integrated circuit containing a processor core, memory, and programmable input/output peripherals. Program memory in the form of Ferroelectric RAM, NOR flash or OTP ROM is also often included on chip, as well as a typically small amount of RAM. Microcontrollers are designed for embedded applications, in contrast to the microprocessors used in personal computers or other general purpose applications

EEPROM: EEPROM (also written E²PROM and pronounced "e-e-prom", "double-e prom", "e-squared", or simply "e-prom") stands for Electrically Erasable Programmable Read Only Memory and is a type of non-volatile memory used in computers and other electronic devices to store small amounts of data that must be saved when power is removed, e.g., calibration tables or device configuration.

When larger amounts of static data are to be stored (such as in USB flash drives) a specific type of EEPROM such as flash memory is more economical than traditional EEPROM devices. EEPROMs are organized as arrays of floating-gate transistors.

RELAY: A relay is an electrically operated switch. Many relays use an electromagnet to mechanically operate a switch, but other operating principles are also used, such as solid-state relays. Relays are used where it is necessary to control a circuit by a low-power signal (with complete electrical isolation between control and controlled circuits), or where several circuits must be controlled by one signal. The first relays were used in long distance telegraph circuits as amplifiers: they repeated the signal coming in from one circuit and re-transmitted it on another circuit. Relays were used extensively in telephone exchanges and early computers to perform logical operations

RELAY DRIVER: A Relay driver IC is an electro-magnetic switch that will be used whenever we want to use a low voltage circuit to switch a light bulb ON and OFF which is connected to 220V mains supply. The required current to run the relay coil is more than can be supplied by various integrated circuits like Op-

Amp, etc. Relays have unique properties and are replaced with solid state switches that are strong than solid- state devices. High current capacities, capability to stand ESD and drive circuit isolation are the unique properties of Relays.

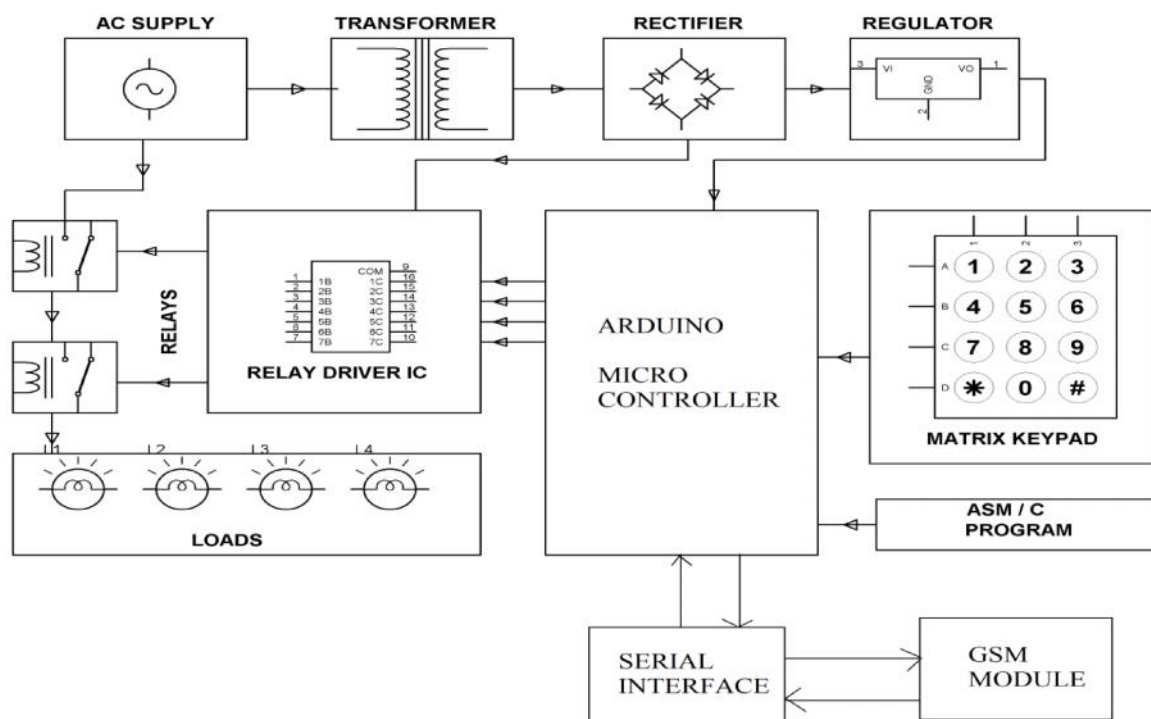

Fig: Block diagram

III. Principle

The main component in the circuit is 8051 microcontroller. In this project 4×3 keypad is used to enter the password. The password which is entered is compared with the predefined password. If entered password is correct then the corresponding electrical line is turned ON or OFF. In this project a separate password is provided to each electrical line. Activation and deactivation of the line (circuit breaker) is indicated by the load.

IV. Working

A) Power supply: The circuit uses standard power supply comprising of a step-down transformer from 230V to 12V and 4 diodes forming a bridge rectifier that delivers pulsating dc which is then filtered by an

electrolytic capacitor of about 470µF to 1000µF. The filtered dc being unregulated, IC LM7805 is used to get 5V DC constant at its pin no 3 irrespective of input DC varying from 7V to 15V.

The input dc shall be varying in the event of input ac at 230volts section varies from 160V to 270V in the ratio of the transformer primary voltage V1 to secondary voltage V2 governed by the formula $V1/V2=N1/N2$. As $N1/N2$ i.e. no. of turns in the primary to the no. of turns in the secondary remains unchanged V2 is directly proportional to V1. Thus if the transformer delivers 12V at 220V input it will give 8.72V at 160V. Similarly at 270V it will give 14.72V. Thus the dc voltage at the input of the regulator changes from about 8V to 15V because of A.C voltage variation from 160V to 270V the regulator output will remain constant at 5V.

The regulated 5V DC is further filtered by a small electrolytic capacitor of 10µF for any noise so generated by the circuit. One LED is connected of this 5V point in series with a current limiting resistor of 330 to the ground i.e., negative voltage to indicate 5V power supply availability. The unregulated 12V point is used for other applications as and when required.

B) Microcontoller pin Configuration:

Microcontroller is interfaced with keypad, EEPROM, relay driver, voltage regulator and C program module.

Out of four ports of microcontroller pin configuration, the upper pins of port 1, i.e., pin 1.0 to pin 1.3 of the microcontroller are connected to the row lines of the keypad and lower pins (pin 1.4 to pin 1.6) are connected to the column lines.

These are connected in such a way that the column lines acts as input to the microcontroller, and the row line as output lines. The input lines are pulled up internally. Here 16x2 LCD is connected to the port 0 and port 2 pins. As the port 0 has no internal pull up, it is pulled up externally using a set of resistors which are connected to 8-data lines of the LCD. And control lines of the LCD are connected to the Port 2 pins

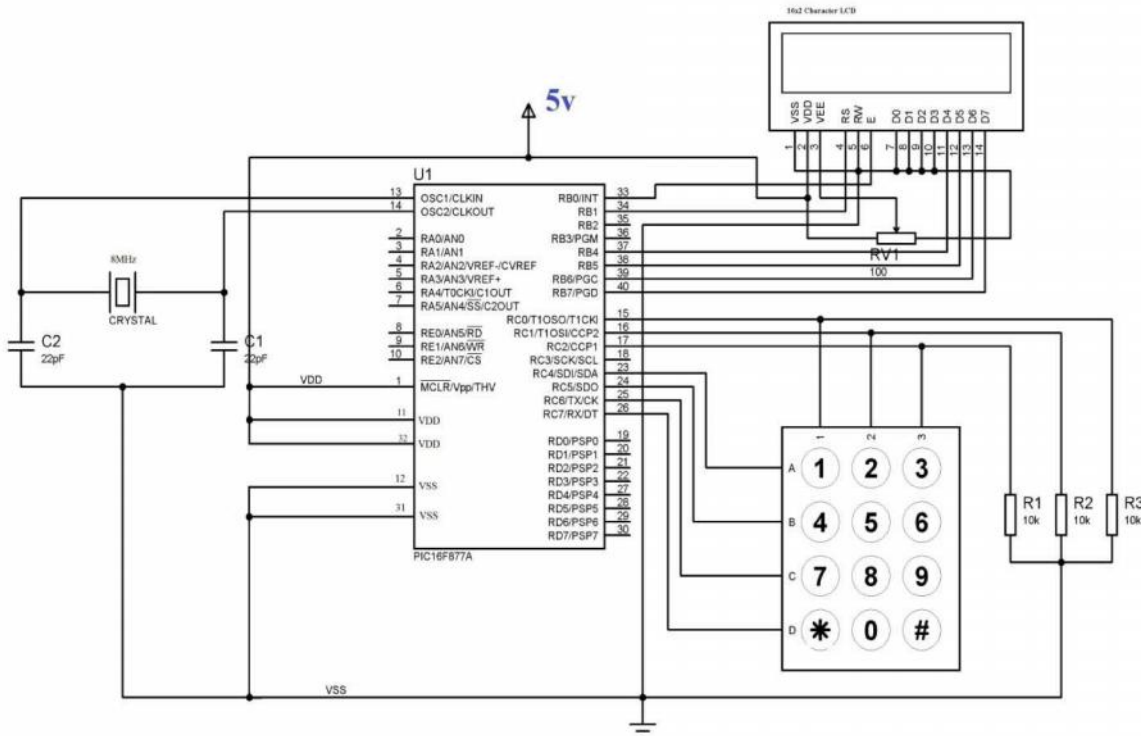

V. Operation

For the operation of circuit breaker through a password, program is written in keil software and created into a .hex file that is further burnt onto the controller with the help of flash magic. Connections are given as per the circuit diagram. While giving the connections, it should be made sure that there is no common connection between AC and DC supplies.

5V power supply circuit is to be used to provide regulated 5V DC to the controller.

Now both the AC and DC supplies are switched on. Relay output pins gets 230V, so they should not be touched. LCD displays “enter password”. Enter the

password with the help of keypad, you can see ‘*’ for each digit. Now if the password is correct then the circuit breaker state changes and displays status line on the LCD screen. If the password is wrong then it displays “access denied”. Since this is a user changeable one, to change the password click on ‘*’, ‘#’. It will display ‘enter password’. Here the circuit is provided with a master code that is used to access the circuit by anyone. For changing the password, this master code is to be entered. Then after entering the master code, LCD displays, ‘new password’. Now any password of will can be entered. After that it displays ‘confirm password’ i.e., the new entered password is going to be stored and the person can change the status of circuit breaker only by this new password.

VI. Results and discussions

This proposed system provides a solution, which can ensure the safety of the maintenance staff e.g. line man. The control to turn ON/OFF the line lies with the line man only. This system has an arrangement such that a password is required to operate the circuit

breaker (ON/OFF). Line man can turn off the supply and comfortably repair it, and return to the substation, then turn on the line by entering the correct password. Since it has the provision of changing the password, person can give any password of his will and have his work done safer.

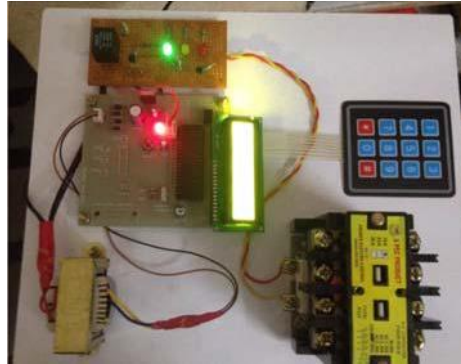

Fig: CB in closed state shown by green LED

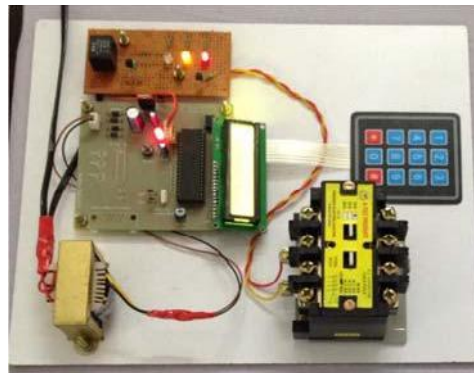

Fig: CB in open state shown by red LED

Conclusion

- It can work on a single given known password
- The password to operate can be changed and system can be operated efficiently with the changed password
- No other person can reclose the breaker once the changed password is given into system other than the person who had changed it.
- It gives no scope of password stealing
- It is effective in providing safety to the working staff
- It is economical
- It can be easily installed

References

1. "The 8051 Microcontroller and Embedded systems" by Muhammad Ali Mazidi and Janice Gillispie Mazidi, Pearson Education.
2. ATMEL 89S52 Data Sheets.
3. "Electrical Engineering Fundamentals" by VINCENT DEL TORO.

Websites

- www.atmel.com
- www.beyondlogic.org
- www.wikipedia.org
- www.howstuffworks.com
- www.alldatasheets.com

Access this Article in Online	
	Website: www.ijarm.com
	Subject: Engineering
Quick Response Code	
DOI: 10.22192/ijamr.2018.05.12.009	

How to cite this article:

A. V. Prathap kumar, K. V. S. S. S. Sairam. (2018). Arduino based lineman protection system with user interface circuit breaker. Int. J. Adv. Multidiscip. Res. 5(12): 84-89.

DOI: <http://dx.doi.org/10.22192/ijamr.2018.05.12.009>