

Research Article

DOI: <http://dx.doi.org/10.22192/ijamr.2018.05.12.010>

## An efficient approach towards tidal power production using vertical planar motion

**Dr.K. V. S. S. S. Sairam, Dr.S.Saravanan, K.Yoganand**

Dhanalakshmi Srinivasan Engineering College, Perambalur

### Abstract

In power production, the tidal energy plays a vital role. This paper deals with the new initiative method to produce energy with latest innovation and cheaper cost. The waves with high force, hits the piston which then pushes the vertical plate. The plate is connected with the dynamo with the help of the shaft to make the motion easy. As the force of the waves gets increased, the dynamo gets rotated and so the power is generated. The power generated from the dynamo is the dc power and this is been stored in the battery. The stored power is then converted as the ac power using the inverter with the help of the transistor 2N3055 which itself also acts as a power booster in order to boost up the power that is generated. As the dc power is converted to the ac power this can be used to run a load.

### Keywords

Transistor 2N3055,  
Vertical plate.

### Introduction

Tidal power, also called tidal energy, is a form of hydropower that converts the energy obtained from tides into useful forms of power, mainly electricity. Although not yet widely used but tidal power has potential for future electricity generation. Tides are more predictable than wind energy and solar power. It is very useful for the coastal states as almost complete south India and partial western part of India is surrounded by sea border. Due to out-dated system, the biggest operating tidal station in the world, La Rance in France, generates 240MW of power but in India it is very less than 50MW. Among sources of renewable energy, tidal power has traditionally suffered from relatively high cost and limited availability of sites with sufficiently high tidal ranges

or flow velocities, thus constricting its total availability. The tidal power is taken from the earth's oceanic tides. Tidal forces are periodic variations in gravitational attraction exerted by celestial bodies. These forces create corresponding motions or currents in the world's oceans.

### Existing system

There are many ways of generating electricity from the tides. One among them is the use of turbines in the oceans. Tidal turbines are very much like underwater windmills except the rotors are driven by consistent, fast-moving currents. The submerged rotors harness the power of the marine currents to drive the generators, which in turn produce electricity.

Water is 832 times denser than air and consequently tidal turbine rotors can be much smaller than wind turbine rotors thus they can be deployed much closer together and still generate equal amount of electricity.

During operation, the force of the tidal flow in Strangford Lough is equivalent to a 345 mph wind generating 100 tonnes of thrust on the rotors.



Fig No: 1 Existing system of tidal power generation using turbines

**Drawbacks of using tidal turbines**

Turbines are not capable of using the full strength of the waves for producing electricity. It produces energy with a very high transmission loss as the boosters used are not that efficient. Moreover the construction cost is high and it also requires special maintenance to monitor whether the blades of the turbines are rusted. The mounting of turbines interrupts the habitat of marine life greatly.

**Overview of the proposed system**

The proposed approach deals with new initiative to produce energy from tides with latest innovation and

cheaper cost. Here the vertical plates are used to create the motion in the shaft which gets transferred to the dynamo. The power produced from the dynamo is boosted by the power booster and it is fed to the battery.

The battery power is then converted to the main current using the inverters made from power transistors 2N3055. This converted power is used for running the loads like glowing the bulb or tube light, charging the laptops or mobile phones, running the table or pedestal fan etc.,

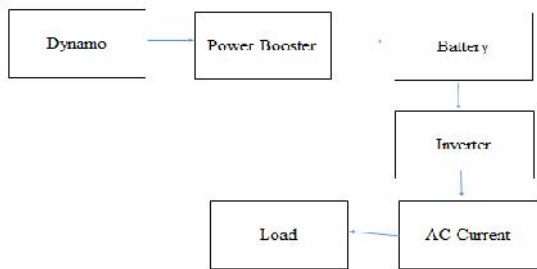

(a)

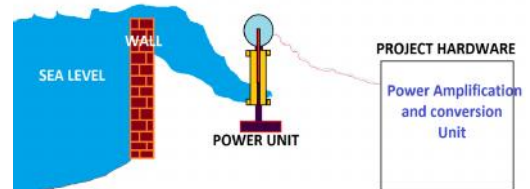

(b)

Fig No: 2 (a) Block diagram of the overall proposed system (b) Working of the overall proposed system

**Working of tides**

Most conventional tidal range schemes use bulb turbines, which are comparable to hydropower turbines that are installed in a dam. Tidal range technology has a number of options for power generation:

- One way power generation at ebb tide: The reservoir is filled at flood tide through sluice gates or valves that are closed once the tide has reached its highest level. At the ebb tide, the water in the reservoir is released through the turbines and power is generated. With this single cycle, power is generated for only four hours per day.
- One way power generation at flood tide: At flood tide the sluice gates are kept closed to isolate the reservoir while at its lowest level. When the tide is high, the water from the sea-side flows into the reservoir via the turbines, thus generating power. The disadvantage of this cycle is that it has less capacity and generates less electricity, and it may be ecologically disadvantageous as the water level in the impoundment is kept at a low level for a long time.
- Two way power generation: Both incoming and outgoing tides generate power through the turbines. This cycle generates power for four hours twice daily. However, reversible turbines are required. La France is an ebb and flood generation plant; bulb turbines can also pump water for optimization.

**Energy of tides**

The energy of tide wave contains two components, namely, potential and kinetic. The potential energy is the work done in lifting the mass of water above the ocean surface. This energy can be calculated as:

$$E = g \int A z dz = 0.5g \int A b^2 \quad (1)$$

Where E is the energy, g is the acceleration of gravity,  $\rho$  is the seawater density, which equals its mass per unit volume, A is the sea area under consideration, z is a vertical coordinate of the ocean surface and h is the tide amplitude. Taking an average  $(g \rho)^{1/2} \approx 10.15 \text{ kNm}^{-3/2}$  for seawater one can obtain for a tide cycle per square meter of ocean surface.

$$E = 1.4b^2, \text{ watt-hour}$$

Or

$$E = 5.04b^2, \text{ kilojoule} \quad (2)$$

The kinetic energy T of the water mass m is its capacity to do work by virtue of its velocity V. It is denoted by  $T = 0.5mV^2$ . The total tide energy equals the sum of its potential and kinetic energy components. Knowledge of the potential energy of the tide is important for designing conventional tidal power plants using water dams for creating artificial upstream water heads.

**Implementation**

**Boosting and conversion of power**

The process in the implementation is assuming that the power generated from the dynamo is stored in the battery. The stored power is connected with the inverter and the power booster which converts the DC power to the AC power. The boosting and inverting of the power, both are done with the help of the transistor 2N3055 itself. So the power is converted to AC power.

The power gets boosted and the input power 12V gets increased as 190V which is nearly equal to 230V 50Hz. This power is capable of running the load by feeding the power to the power grid.

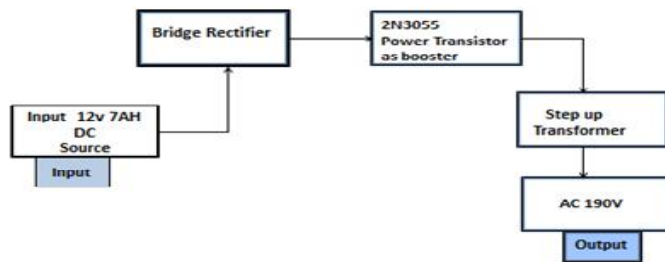

Fig No: 3 Block diagram of boosting and conversion of power

**Related works**

**Inverter**

The inverter circuit consisting of the different components with their specification is given in the

circuit diagram and the components are been explained below.

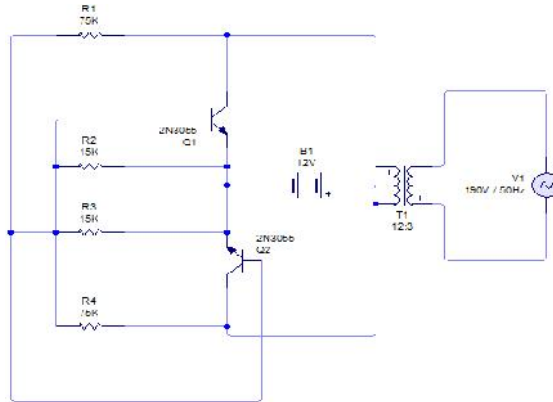

Fig No: 4 Circuit diagram of the inverter

**Features of the battery and its specification**

The battery is assumed to be the input source in the implementation. The power stored in the battery is assumed as the power generated from the dynamo rotation with the to-and-fro motion of the tidal waves. The input power from the battery is 12V and 7 AH DC source which is the capacity of the battery that is been used for the implementation. The model number of the battery used is **EXIDE CS 7-12**. This power from the battery is fed to the bridge rectifier.

**Bridge rectifier**

The power from the battery is fed to the bridge rectifier. The bridge rectifier is used in the setup in order to manage the polarity problems. The entire setup will not be damaged and will have the same output even if the wires in the battery are connected wrongly to the positive and negative terminals. The other use of this bridge rectifier is to prevent the damage of the transistor by passing the current in the reverse direction. The power is then transferred to the power transistor 2N3055.

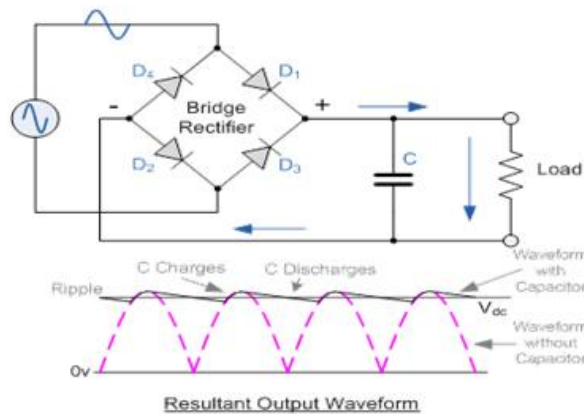

Fig No: 5 Circuit diagram and output waveform of bridge rectifier

### Power transistor 2N3055

This power transistor used in the setup is 2N3055. This transistor helps in both inverting the power from DC to AC as well as in boosting the power. This

transistor has the capacity of boosting the power which is been checked out practically. The power transistor is used in the setup in order to withstand the high current passage and to avoid damage of the circuit due to high passage of current.

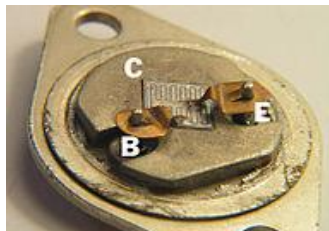

Fig No: 6 Internal parts of transistor 2N3055

### Power transformer

Transformer plays a most important role in this setup. The input 12V from the battery is fed to the power transformer which also plays the role of boosting the power. The 12V power is boosted and given at the output as 190V which is nearly equal to 230V that is capable of running the load. The transformer used here is the step-up transformer which is normally used to increase the voltage and the current is decreased at the output.

### Result and output Discussion

As a result the given 12V DC source is converted to the AC source and the power is boosted to 190V which is capable of running the load like glowing the bulb, running the table fan, charging the laptops or mobile phones. The input taken in the battery is the assumption that the power generated from the rotation of the dynamo due to tidal waves is stored in the battery.

### Hardware modules



Fig No: 7 Output Representation

## Conclusion

Tides play a very important role in the formation of global climate as well as the ecosystems for ocean habitants. At the same time, tides are a substantial potential source of clean renewable energy for future human generations. Depleting oil reserves, the emission of greenhouse gases by burning coal, oil and other fossil fuels, as well as the accumulation of nuclear waste from nuclear reactors will inevitably force people to replace most of our traditional energy sources with renewable energy in the future. Tidal energy is one of the best candidates for this approaching revolution. Development of new, efficient, low-cost and environmentally friendly hydraulic energy converters suited to free-Sow waters. In our project, a new method is purposed to produce power from tidal wave in much extended way.

As discussed in the above sections if the whole concept is implemented throughout the country, it creates a boom in power production sector by producing at least 65% of total energy required nationwide.

## References

1. Ben Elghali, (2007) "Marine Tidal Current Electric Power Generation Technology: State of the Art and Current Status" IEEE International Electric Machines & Drives Conference, vol-2.
2. Douglas, C. A.; Harrison, G. P.; Chick, J. P. (2008). "Life cycle assessment of the Seagen marine current turbine". Proceedings of the Institution of Mechanical Engineers, Part M: Journal of Engineering for the Maritime Environment. 222 (1): 1–12. doi:10.1243/14750902JEME94.
3. Federal Energy Regulatory Commission (2006) "Hydropower industry activities: Tidal energy issued and pending permits." Accessed online at: <http://www.ferc.gov/industries/hydropower/industry-act/tidalenergy-permits/permits.asp>
4. Johnson, J. (2004) "Power from moving water." Chemical and Engineering News, 82(40): 23-30 .
5. Lotie, B. (2003) "A new wave of energy." Bulletin of the Atomic Scientists, 59 (6):8-9.
6. Lewis, M.; Neill, S.P.; Robins, P.E.; Hashemi, M.R.(2015) "Resource assessment for future generations of tidal-stream energy arrays". Energy. 83: 403–415. doi:10.1016/j.energy.
7. Norling, J. (2006) "Catching wave energy." NWCurent.com. Accessed online at: <http://www.nwcurrent.com/renewbl/more/378947.html>
8. Ocean Energy Council (2011). "Tidal Energy: Pros for Wave and Tidal Power"

Access this Article in Online	
	Website: <a href="http://www.ijarm.com">www.ijarm.com</a>
	Subject: <a href="#">Engineering</a>
Quick Response Code	
DOI: <a href="https://doi.org/10.22192/ijamr.2018.05.12.010">10.22192/ijamr.2018.05.12.010</a>	

### How to cite this article:

K. V. S. S. S. Sairam, S.Saravanan, K.Yoganand. (2018). An efficient approach towards tidal power production using vertical planar motion. Int. J. Adv. Multidiscip. Res. 5(12): 90-95.  
DOI: <http://dx.doi.org/10.22192/ijamr.2018.05.12.010>